

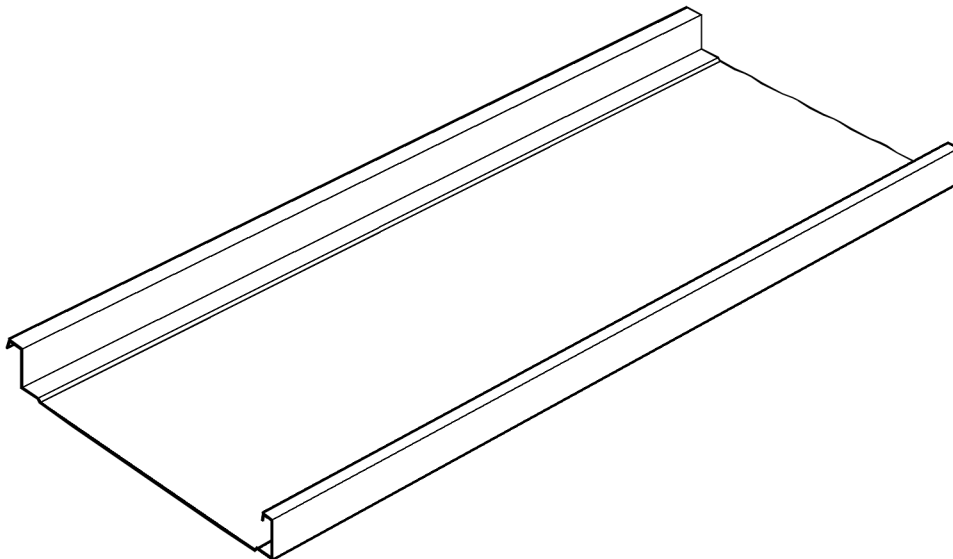

BIGBEE STEEL BUILDINGS, INC.
2705 Avalon Avenue
Muscle Shoals, AL 35661

BigbeeVR
Standing Seam Roof System

SEAMING GUIDE



Phone: 256-383-7322 or 800-633-3378
Fax: 256-381-9669
www.bigbee.com

Revised: Aug. 14, 2024

INDEX

1.0 Introduction

1.1 General.....	1-1
------------------	-----

2.0 SEAMING EQUIPMENT

2.1 Specialized Seaming Tools.....	2-1
2.2 Seaming Tool Source	2-1
2.3 Seaming Kit	2-1
2.4 Receiving and Shipping.....	2-2
2.5 Handling and Storage.....	2-2
2.6 Electrical Requirements.....	2-2
2.7 Electrical Service and Cords	2-2
2.8 Electrical Safety	2-3
2.9 Insurance.....	2-3

3.0 SEAM TYPES

3.1 General.....	3-1
3.2 TripleLok™ Seam	3-1
3.3 QuadLok™ Seam.....	3-1

4.0 IMPORTANCE OF SEAMING

4.1 Roof Performance	4-1
4.2 When to Seam.....	4-1
4.3 Temporary Seaming	4-1

5.0 CHECK PANEL ASSEMBLY

5.1 Sidelap Fit-up	5-1
5.2 Clip Alignment.....	5-1
5.3 Seam Damage.....	5-1

6.0 MANUAL SEAMING TOOL OPERATION

6.1 Primary Manual Seaming Tool Nomenclature	6-1
6.2 Assemble Seaming Tool	6-1
6.3 Tool Orientation to Seam	6-1
6.4 Forming the Seam	6-2
6.5 Tool Position at End of Roof Panel.....	6-3
6.6 Tool Position at End Roof Panel Endlap.	6-3
6.7 Tool Position at Panel Clips.....	6-4
6.8 Checking the Finished Seam.....	6-4
6.9 Secondary (QuadLok) Hand Seamer	6-5
6.10 Hand Forming Secondary (QuadLok) Seam	6-5
6.11 Checking the Finished Seam.....	6-5

7.0 OPERATING THE MOTOR SEAMING MACHINE

7.1 One Direction Seaming Machine Nomenclature	7-1
7.2 Machine Orientation to Seam	7-2
7.3 Machine Position on Roof Panel	7-2
7.4 Starting Seams	7-2
7.5 Clean the Seams	7-3
7.6 Running the Machine.....	7-3
7.7 Stopping the Machine.....	7-3
7.8 Un-locking the Machine	7-3
7.9 Checking the Finished Seam.....	7-3
7.10 Bi-Directional (Flip-Flop) Seaming Machine Nomenclature.....	7-4
7.11 Difference in Seaming Direction	7-4
7.12 Locking the Machine to the Seam	7-5
7.13 Starting the Seaming Process	7-5
7.14 Un-locking the machine	7-5
7.15 Flipping the Bi-Directional Machine	7-6

8.0. Motor Seaming Machine Maintenance

8.1 General.....	8-1
8.2 Seaming Rolls	8-1
8.3 Cooling Vents	8-1

9.0. Trouble Shooting Guide

9.1 Manual Seaming.....	9-1
-------------------------	-----

We do not provide the seamers or hand tools. Erector must get them direct from Developmental Industries, Inc.

1.0 Introduction

1.1 General

The seaming guide is provided by Bigbee Steel Buildings, Inc. (BSB) to you the customers and erectors as the recommended procedures for the correct seaming of the BSB **BigbeeVR** Standing Seam Roof System.

This guide is intended to be used with the BSB **BigbeeVR** Standing Seam Roof System Installation Guide and the project's erection drawings.

The erection drawings govern the specific seam requirements. In case of conflict between this installation guide and the erection drawings, the erection drawings will have precedence.

The customer is responsible for proper seaming of the roof in accordance with the erection drawings and this seaming guide, and in accordance with good engineering and construction practices.

The customer must take the responsibility for selecting a competent erector, insist that the work be performed by qualified and experienced standing seam metal roof installers, insist that the erector take time to study and understand this guide, then assure that the erector correctly follows the guide's instructions.

BSB does not guarantee and is not liable for the quality of erection. BSB is not responsible for building defects that may be attributed to improper erection or the negligence of other parties.

The following seamer equipment depicted in this manual is for seamers manufactured, provided and serviced by Developmental Industries, Inc (DI) and are the only seamers approved to be used on BSB's **BigbeeVR** standing seam projects.

Clarification concerning the BSB roof installation and seaming should be directed to the BSB Customer Service Manager. Contact the BSB Office:

BIGBEE STEEL BUILDINGS, INC.
2705 Avalon Ave.
Muscle Shoals, AL 35661
Phone: 256-383-7322
800-633-3378
Fax: 256-381-9669
www.bigbee.com

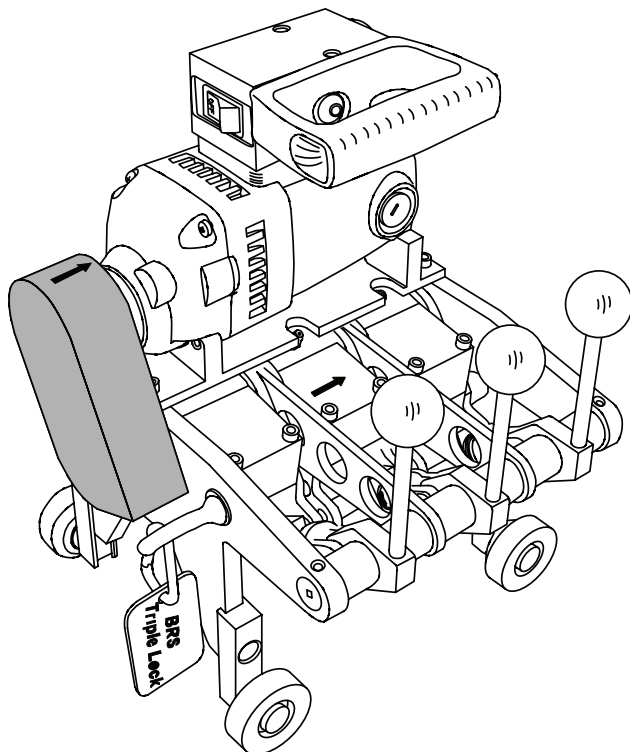

Motor Seaming Machine

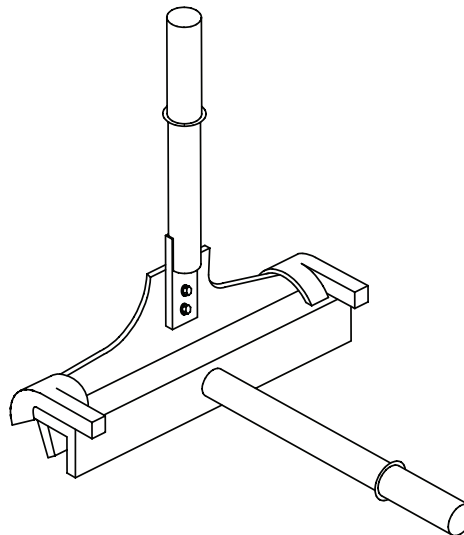

Manual Seaming Tool



2.0 SEAMING EQUIPMENT

2.1 Specialized Seaming Tools

The seaming of the BSB roof panels require special seaming tools which are available only through DI.

Caution: The use of other or unapproved seaming equipment may result in faulty and/or damaged seams and will invalidate the roof system's material and performance warranties.

2.2 Seaming Tool Source

The seaming tools are provided by DI in accordance to the terms and conditions of the DI Roof System seamer rental or purchase contract.

Contact the DI Customer Service Department to arrange the scheduling, delivery and return of the seaming tools.

Developmental Industries, Inc.
915 Highway 45
Corinth, MS 38834
phone: 888-343-0456 • fax: 662-287-6744
www.bigbee.com

2.3 Seaming Kit

The seaming equipment will normally be provided as a seaming kit. The seaming kit will consist of the following:

- a. Seaming Kit Chest (contains and protects the seaming tools during shipment and storage).
- b. Motor Seaming Machine (provided only for **Tri-pleLok** or **QuadLok** seaming)
- c. Return shipping documents
- d. Repair parts, hex and end wrenches

- e. Seaming Guide.
- f. Primary Manual Seaming Tool and/or
- g. Secondary Seaming Tool

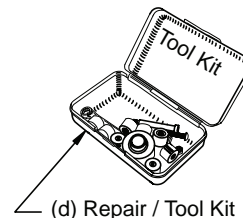
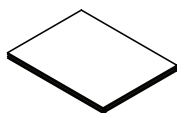
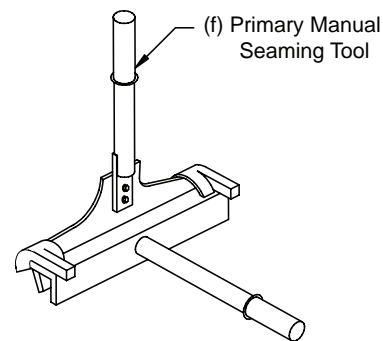
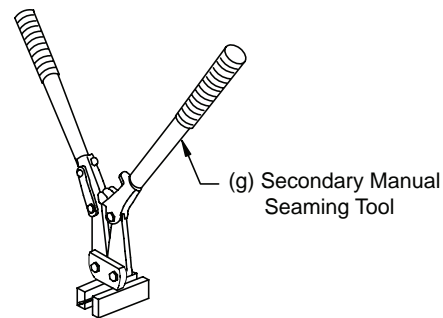
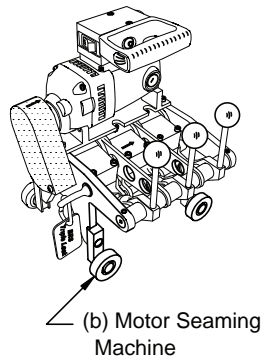
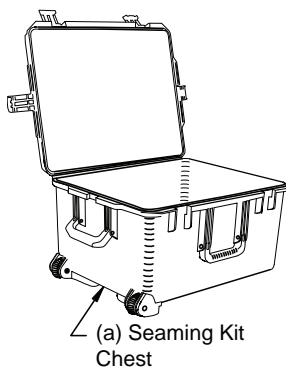

2.0 SEAMING EQUIPMENT (Cont'd.)

2.4 Receiving and Shipping

Upon receipt of the seaming kit, and before signing the shipping receipt, verify that the seaming kit is received in good condition without damage or loss of contents.

If there is damage or loss of contents, immediately file the claim with the shipper and notify DI for replacement instructions.

Upon completion of the roof seaming, promptly return the seaming kit to DI in accordance with the instructions on the return shipping documents. The return shipping documents are provided in the seaming kit. All materials must be returned (even worn rollers) intact and failure to do so will result in a charge for missing items.

2.5 Handling and Storage

Provide safe and secure handling of the seaming tools when in use.

The motor seaming machine weighs at least 65 lbs. and can cause severe damage and injury if it falls and should be tethered at all times.

The machine may be too heavy to safely carry up a ladder. Always hoist the machine onto the roof with proper lifting equipment or with a proper sized rope/tether tied or hooked securely to the machine's lifting eye.

Caution:

- When starting and finishing the seaming machine at the edges of the roof, the operator and machines must be securely positioned and tethered so that he can safely lift the seaming machine on and off of the seam.
- When running the machine in the downslope direction, the seaming machine will have greater downhill inertia and coasting distance.
- When not locked to the seam, the motor seaming machine can freely roll on its wheels. Always secure the machine to prevent its rolling or sliding off the roof.
- At the days end or when the seaming tools are not in use, they must be stored in the seaming kit chest and the chest secured in a safe and dry area. The seaming tools must be cleaned and dried before storing.

2.6 Electrical Requirements

The seaming machine motor requires a minimum electrical power supply of 20 amp @ 120 Volt @ 60 hz AC.

2.7 Electrical Service and Cords

The electrical service and the electrical cords to the seaming machine must be of sufficient capacity to provide the full 20 amp @ 120 Volts **at the seaming machine**. If other tools or equipment are being used on the same service, the service and cord capacity must be increased accordingly.

Caution: Low voltage due to insufficient service capacity, insufficient cord size or excessive cord length will cause overheating and burnout of the seaming machine's motor.

RECOMENDED EXTENSION CORD SIZE				
Distance (Ft)	0 - 50	50 - 100	100 - 200	200 - 300
Wire Gauge	12	10	8	6



2.0 SEAMING EQUIPMENT (Cont'd.)

2.8 Electrical Safety

Check that the power cords are fitted with the correct plug for safe and secure electrical connection to the seaming machine. Check that the power cords are properly grounded and that the service has a ground fault circuit breaker.

Check that the electrical cord is of sufficient length to extend the full length of the area to be seamed without stress on the cord or its connections. Check that the path for the cord is clear and that the cord is clear of snagging on panel edges or entanglement into the seaming machine rolls.

2.9 Insurance

The DI Roof System seaming tools are custom built, specialized equipment and are costly to replace. You should provide adequate insurance coverage on the seaming tools while they are in your possession and use.

3.0 SEAM TYPES

3.1 General

The BSB **BigbeeVR** Standing Seam Roof System has two seam type options. The project's design and roof performance requirements govern which seam type is required.

Different seam types may be required on specific areas of the same roof. In all cases, refer to the erection drawings to determine the required seam type and location.

3.2 TripleLok™ Seam

The **TripleLok** Seam requires seaming the roof panel with the manual seaming tool at the eave, ridge end of the roof panel and at the endlaps. Then seaming the full length of the roof panels with the motor seaming machine.

The motor seaming machine must be fitted with the **TripleLok** seaming rolls.

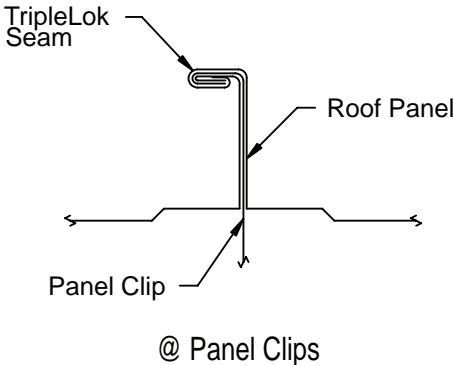

3.3 QuadLok™ Seam

The **QuadLok** Seam requires that the roof panels be previously TripleLok seamed. The starting point must be hand seamed with the secondary hand seamer.

Then re-seaming specified areas of the roof with the motor seaming machine. The motor seaming machine must be fitted with the **QuadLok** seaming rolls.

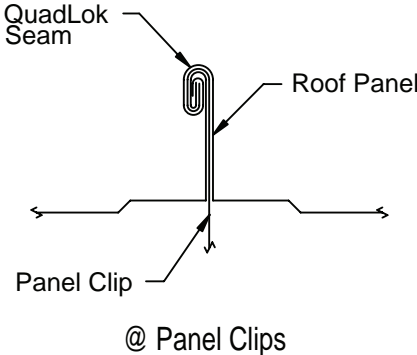

4.0 IMPORTANCE OF SEAMING

4.1 Roof Performance

The roof panels must be correctly seamed before the roof system can provide its designed wind load and weather resistance capability. This means that an un-seamed or improperly seamed roof is subject to wind load failure and/or weather resistance failure.

4.2 When to Seam

Whenever possible, the installed roof panels should be seamed at the finish of each days work. If high wind or rain/snow conditions are imminent, the installed roof panels **must be seamed** before such conditions occur.

4.3 Temporary Seaming

On roofs requiring **TripleLok** and **QuadLok** seams, it may not always be practical or feasible to motor seam the roof panels until after the roof installation is completed. Motor seamed roof panels are difficult to reposition or replace and seaming machines may not always be available during the entire roof installation period.

In such cases, it may be desirable to temporarily manual hand seam the roof panels at the panel ends, clips and end laps with the manual seaming tool, then later complete the seaming with the motor seaming machine.

Since temporary seaming is a practical approach, it would be advisable to buy several hand seamers to keep for use on a job by job basis. There will be a hand seamer sent with each motorized seamer order, how ever its arrival to the jobsite is usually too late in the sheeting process to insure against any sudden weatherchanges or safety issues...

Important: Any temporary seaming must be approved by the project's designer.

Note: The temporary seaming process/procedure is identical to the steps taken to prepare for the primary **TripleLok** seaming operation.

5.0 CHECK PANEL ASSEMBLY

5.1 Sidelap Fit-up

Before seaming, inspect the full length of each roof panel sidelap. Check that the male and female are fully nested and the lip at the panel's male edge is enclosed by the hook of the adjacent panel's female edge.

Any conditions where the male and female are not fully nested or the male lip is not positioned inside of the female hook **must be corrected** before attempting to seam the roof panels.

Caution: Faulty seaming may occur where the male lip is not enclosed by the female hook and when the male and female are not fully nested. Such faulty seaming can result in seaming difficulty and objectionable seam appearance. In severe cases reduction in roof performance specifications.

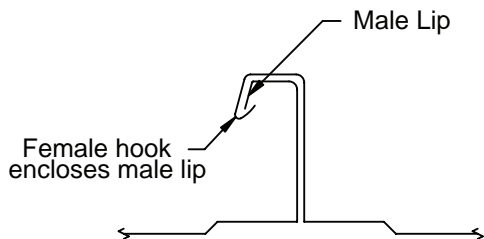

Correct

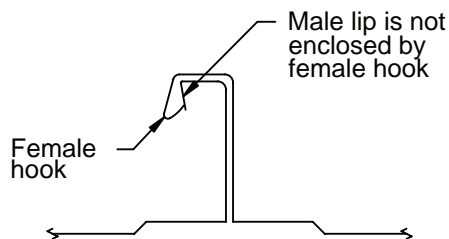

Wrong
(false seamed)

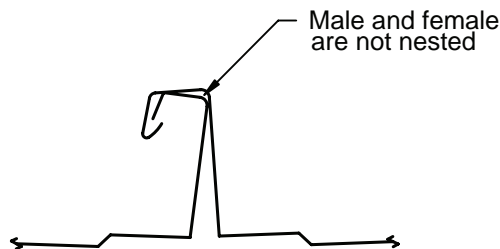

Wrong
(not nested)

5.2 Clip Alignment

Before seaming, check that each roof panel clip is properly seated in the roof panel sidelap assembly. **Any displaced clips must be corrected before attempting to seam the roof panels.**

Caution: Misaligned panel clips can cause faulty seaming and objectionable seam appearance.

5.3 Seam Damage

Before seaming, check that the male and female edges are not kinked or otherwise distorted. **Any such distortions must be corrected before attempting to seam the roof panels.**



6.0 MANUAL SEAMING TOOL OPERATION

6.1 Manual Seaming Tool Nomenclature

The following detail identifies the operational parts of the manual seaming tool.

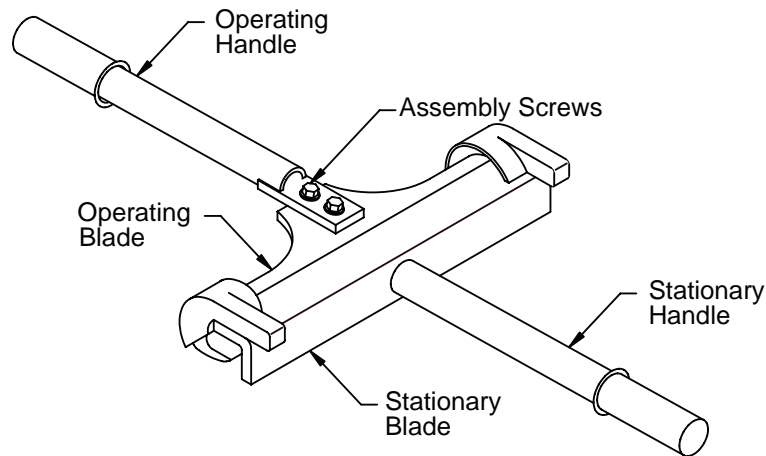

6.2 Assemble Seaming Tool

When received, the manual seaming tool may be unassembled. Assemble the handle to the tool body and secure with the provided screws/bolts.

6.3 Tool Orientation to Seam

Orient the tool to fit correctly onto the roof panel seam as shown. The stationary handle must be in the horizontal position and the operating handle must be rotated up to the open position.

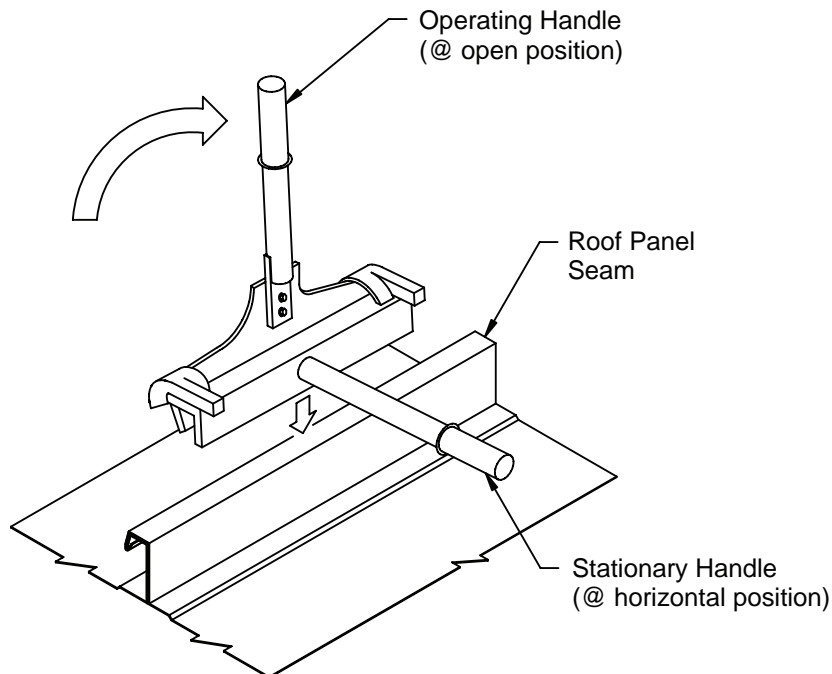

6.0 MANUAL SEAMING TOOL OPERATION (Cont'd.)

6.4 Forming the Seam

When the tool is correctly positioned on the panel, push the stationary blade down solidly against the top of the

seam. While holding the stationary handle in the horizontal position, rotate the operating handle down to the horizontal position. This will form the seam.

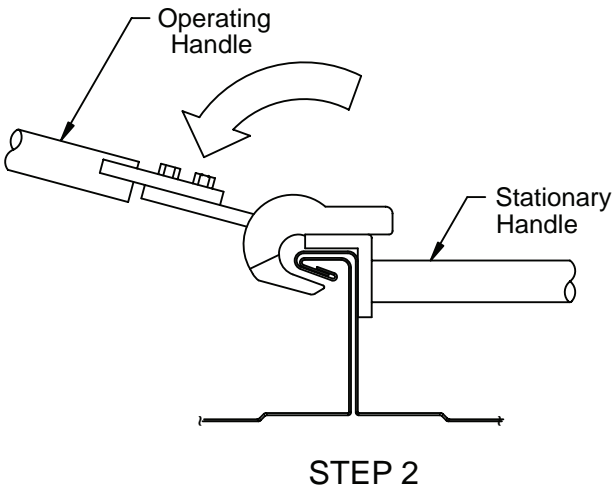
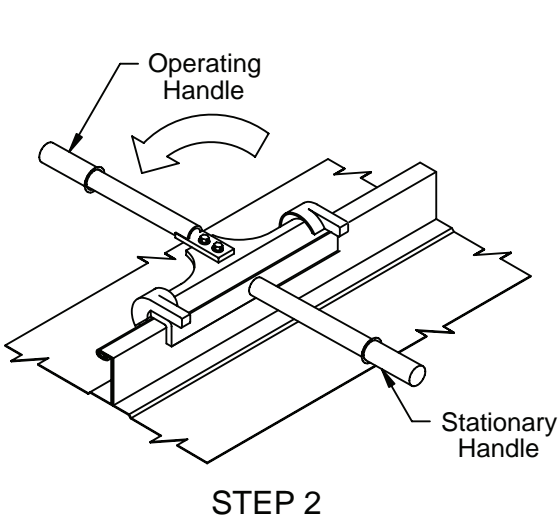
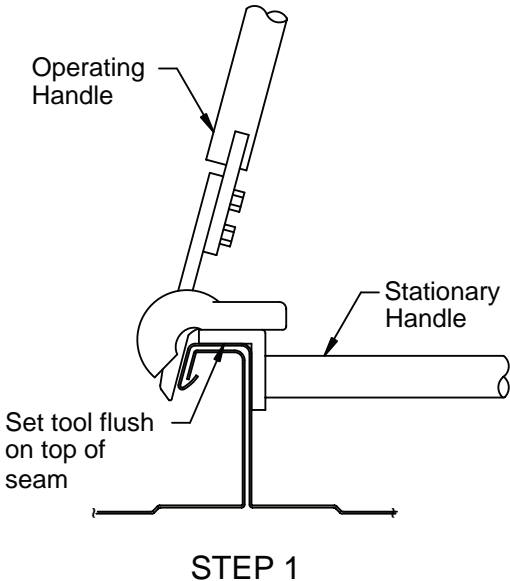
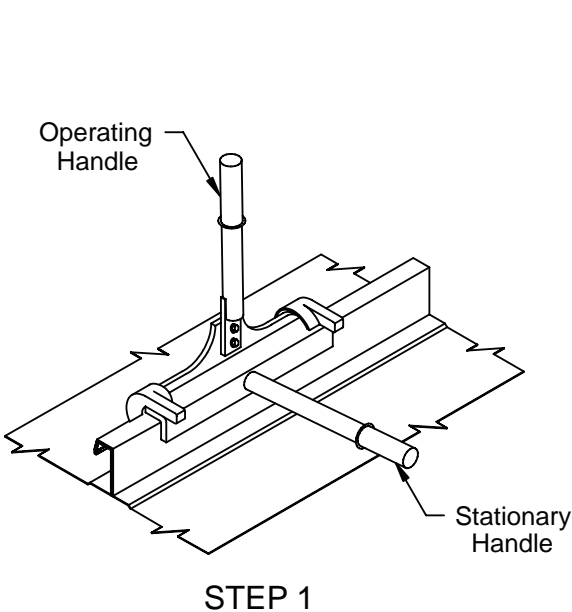

6.0 MANUAL SEAMING TOOL OPERATION (Cont'd.)

6.5 Tool Position at End of Roof Panel

When seaming at the eave or ridge end of the roof panel, the seaming must be done in two steps.

For the second step, position the end of the seaming tool flush with the end of the roof panel and seam that area.

For the first step, position the end of the seaming tool at 6" from the end of the roof panel and seam that area.

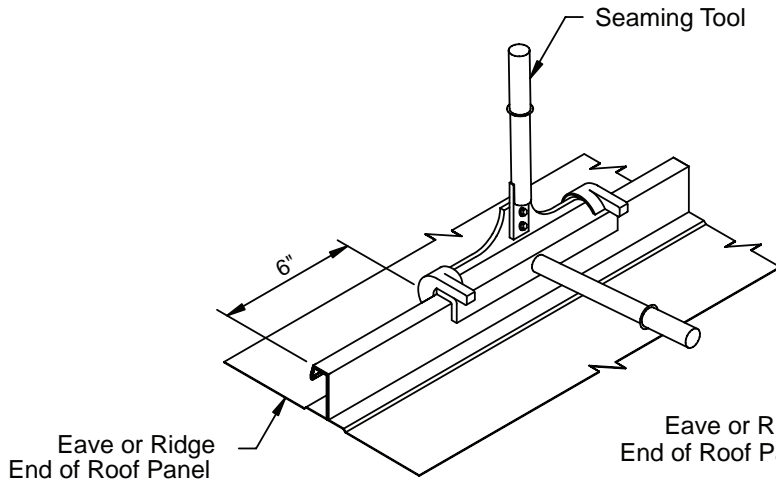

STEP 1

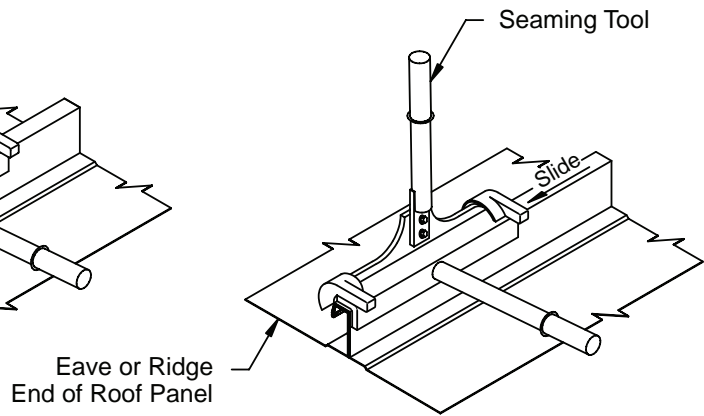

STEP 2

6.6 Tool Position at Roof Panel Endlap

When seaming at a roof panel endlap, the seaming must be done in two steps.

For the second step, position the end of the tool 3" uphill from the edge of the endlap and seam that area. This is to allow the uphill "pig tail" sealant to properly flow and allow the motorized seamer to properly function at the lap.

For the first step, center the tool over the endlap and seam that area.

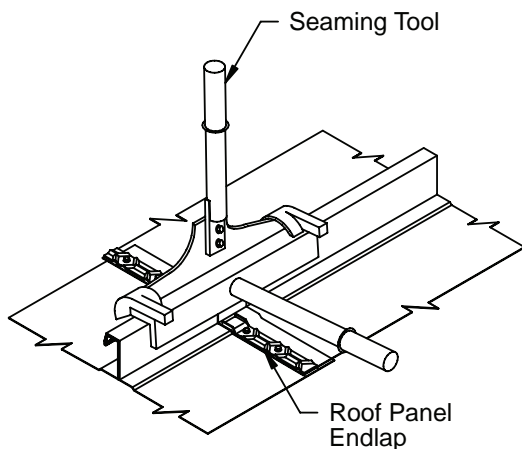

STEP 1

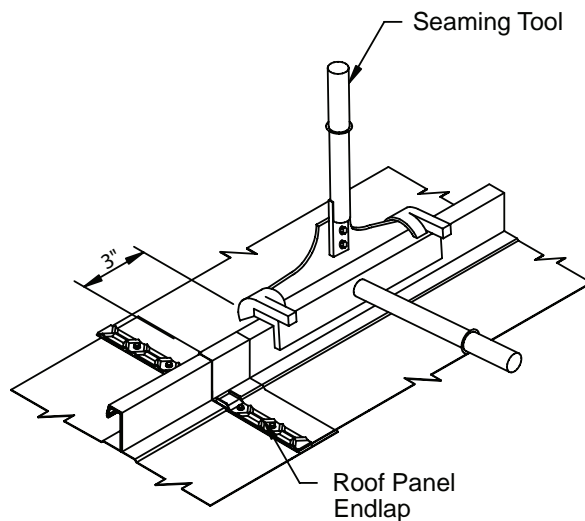

STEP 2

6.0 MANUAL SEAMING TOOL OPERATION (Cont'd.)

6.7 Tool Position at Panel Clips

When seaming at a panel clip location, center the tool over the panel clip and seam that area.

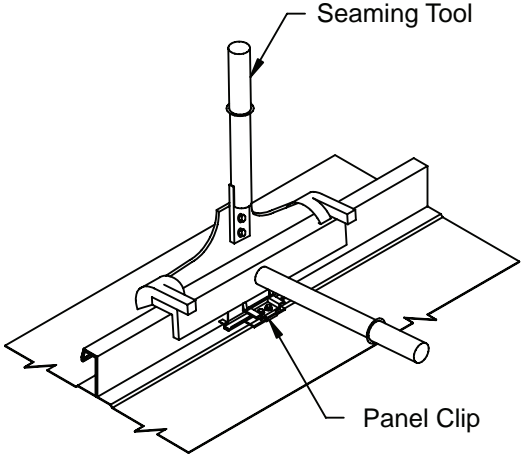

@ PANEL CLIPS

6.8 Checking the Finished Seam

Rotate the operating handle to the open position, remove the tool and check that the seam is correctly formed, as shown on the detail below.

Caution: If the manual seaming tool does not correctly form the seam, do not continue seaming but contact BSB for instructions.

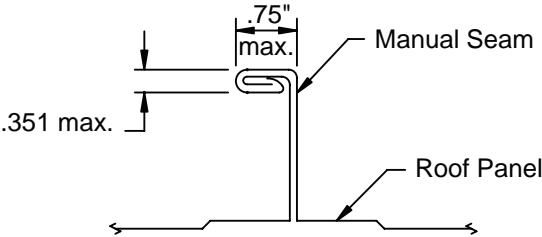

6.0 MANUAL SEAMING TOOL OPERATION (Cont'd.)

6.9 Secondary Manual Hand Seamer ("QuadLok")

The secondary manual hand seamer requires no assembly.

This seamer is only used at the start location on each seam for the **QuadLok** secondary motorized seamer. Before using this manual hand seamer the entire seam must be TripleLok seamed using the primary motor seamer.

6.10 Hand Forming the Secondary Seam ("QuadLok")

Step 1. To begin, simply spread the handles to open the forming jaws making sure the female notch is set properly over the seam. Close the handles to form the seam. Slide up the seam and form again until 8" of seam is preped.

Step 2. Rotate hand seamer so the flat forming plate is against the formed part of the seam and close the handle to complete the **QuadLok** preparation.

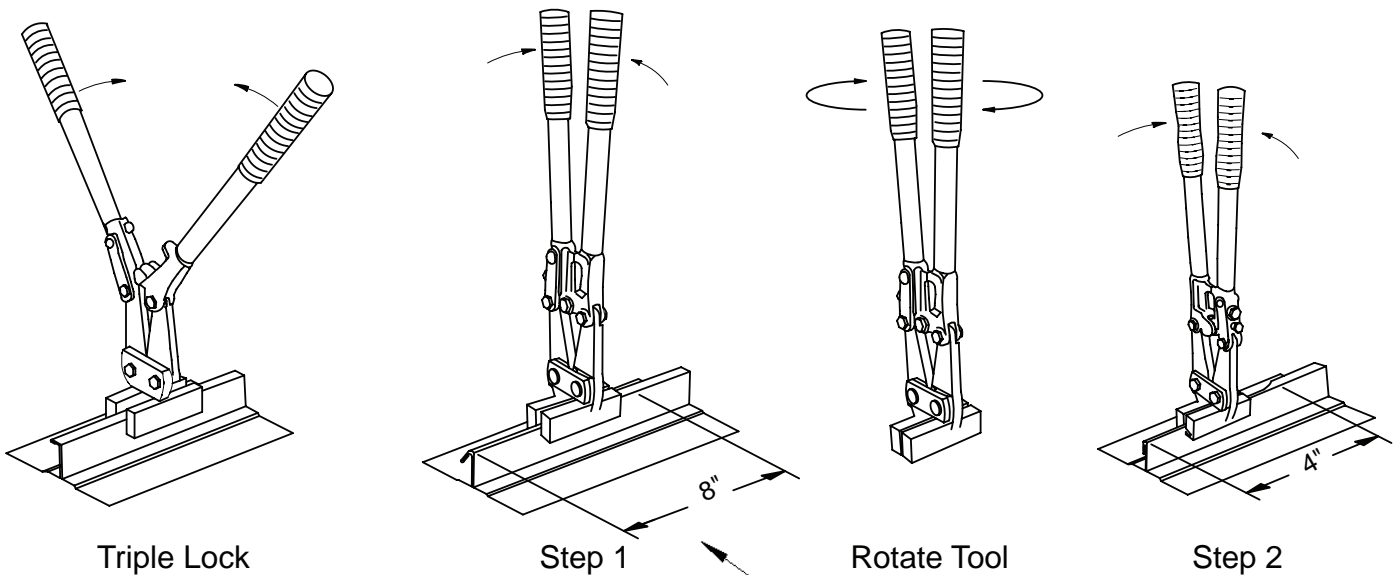

6.11 Check the Finished Seam

Remove the hand seamer and check that the seam is properly made between steps.

Caution: If the seaming tool does not form a proper seam do not continue. Call BSB for assistance.

If SSGS-2 type Gutter Straps are required DO NOT QuadLok seam the first 6" of the panel from the eave at Gutter Strap locations. See page 9-70 of the BigbeeVR Installation Guide for more details.

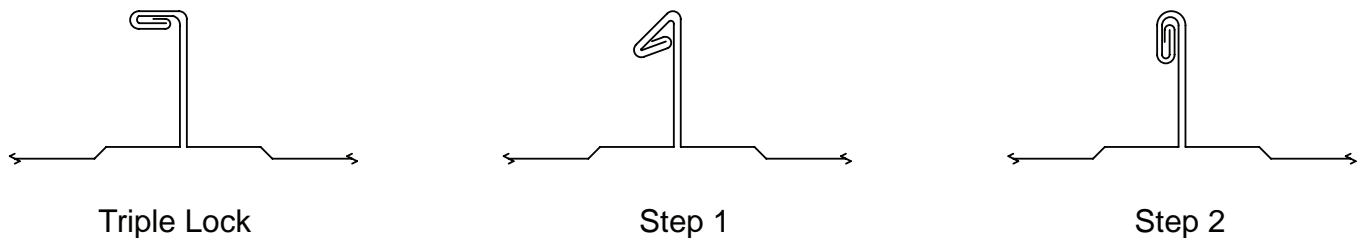

7.0 OPERATING THE MOTOR SEAMING MACHINE

7.1 One Direction Seaming Machine Nomenclature

The following details identify the operational parts of the one direction primary (**TripleLok**) and secondary (**QuadLok**) motor seaming machines.

The cam follower is used only for **TripleLok** seaming and will not be found on machines set-up for **QuadLok** seaming.

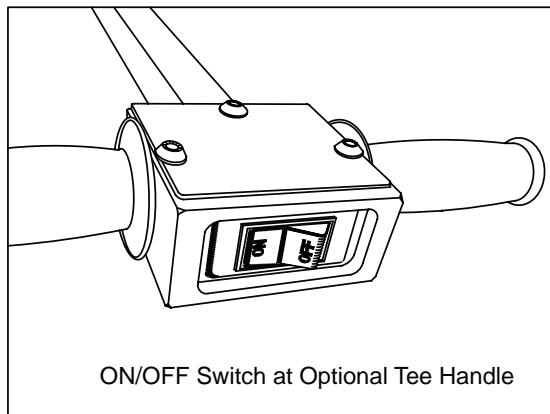
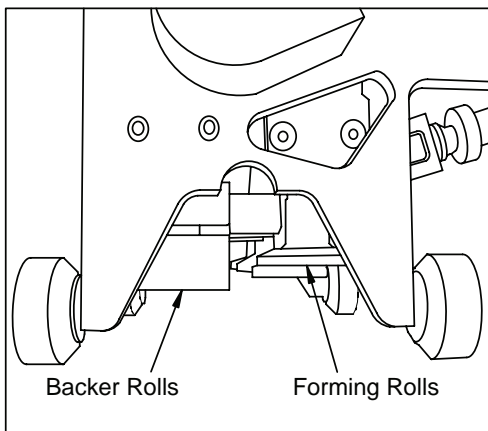
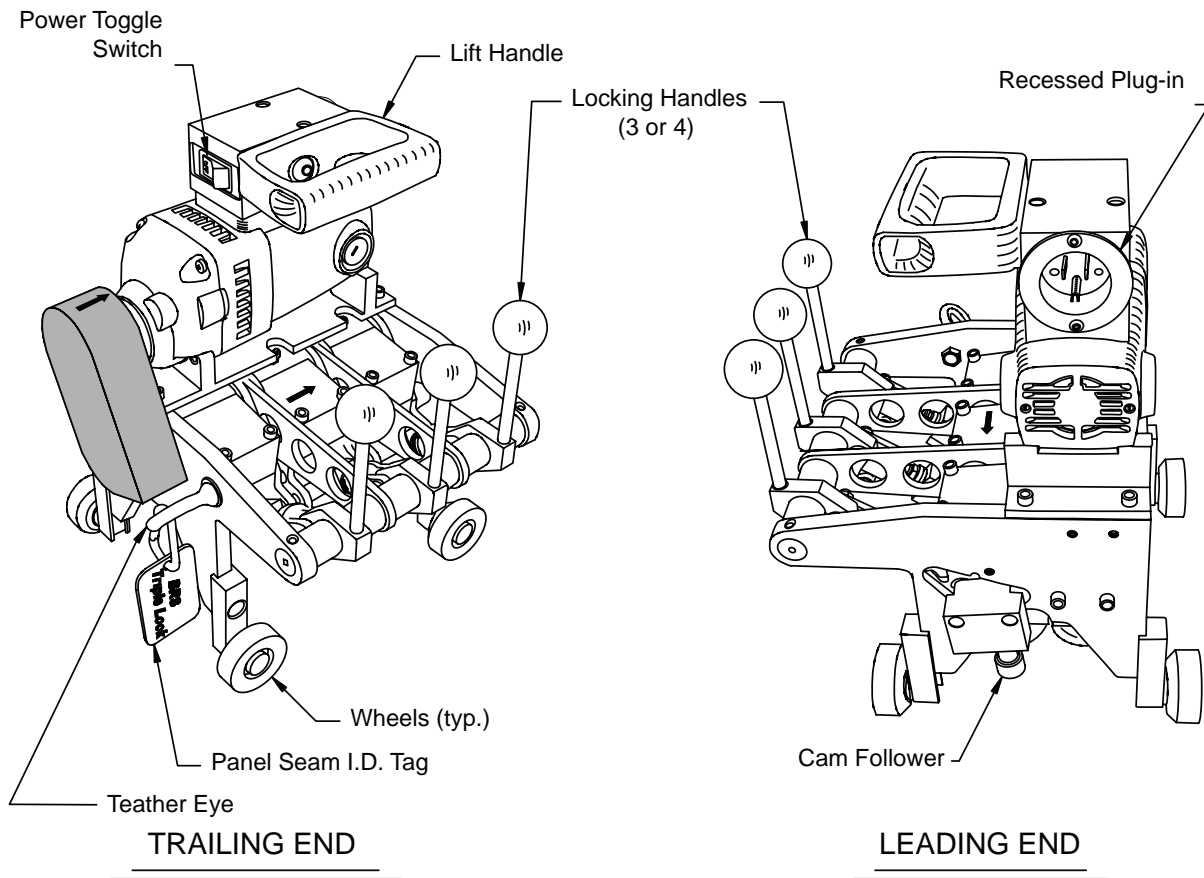

7.0 OPERATING THE MOTOR SEAMING MACHINE (Cont'd.)

7.2 Machine Orientation to Seam

On roofs sheeted from left to right, the seaming machine will run from the eave to the ridge.

On roofs sheeted from right to left, the seaming machine will run from the ridge to the eave for one directional machines.

7.3 Machine Position on Roof Panel

With the locking handle held up in the open position, set the seaming machine onto the starting end of the roof panel's seam over the manually seamed portion of the seam.

If the locking handle will not readily lock, roll the machine forward or backward slightly until a position is found where the locking handle will readily lock. If the locking handle still does not lock, check the handseaming to be sure it is in the proper form.

Roll the seaming machine forward to align the front seaming rolls over the un-seamed portion of the seam as shown in the detail below.

Once the locking handle is locked, check that the forming rolls are properly engaged.

When the machine is in the correct position on the seam, pull the locking handle out to the locked position. The locking handle should lock with minimal resistance when force is applied.

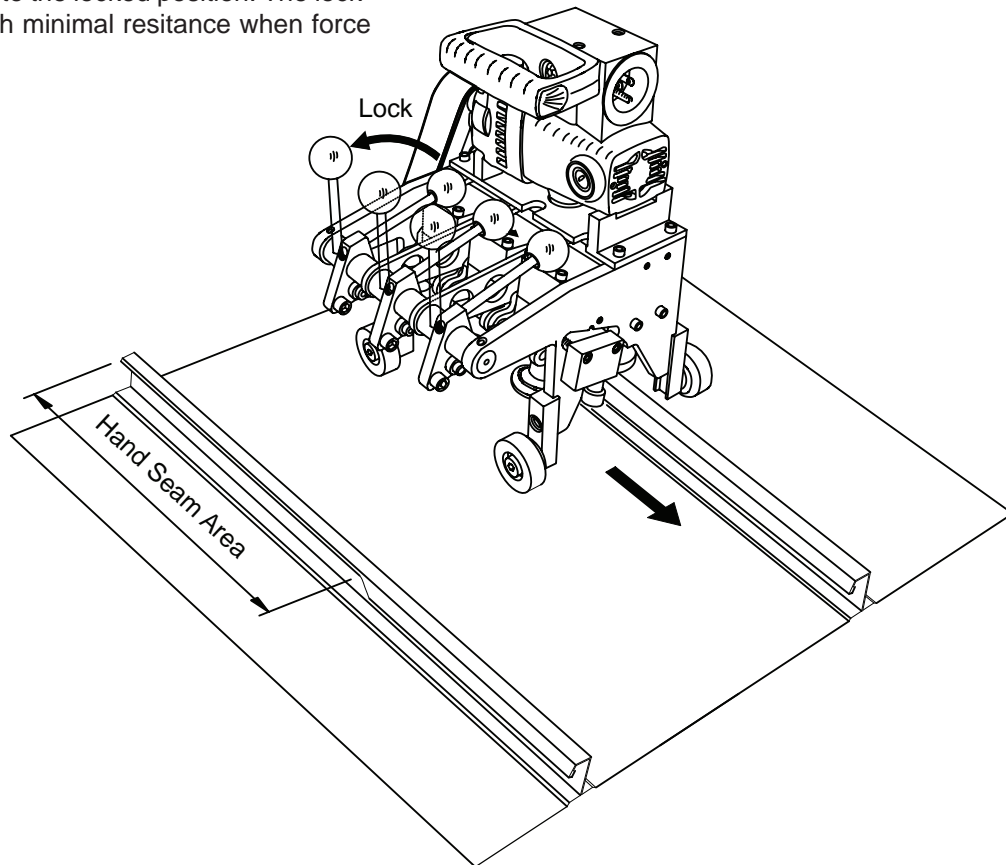

7.4 Starting Seams

For **TripleLok** seaming use the seaming machine that is marked "Primary", which must start on a portion of seam which has already been seamed with the manual seaming tool. Depending on which direction the seaming machine will be run, form the starting seam at the eave or ridge end of the roof panels with the manual seaming tool as described in section 6.0.

For **QuadLok** seaming use the seaming machine that is marked "Secondary", which must start on a portion of seam which has already been fully **TripleLok** seamed and preped with the secondary manual seaming tool. Depending on which direction the seaming machine will be run, form the starting seam at the eave or ridge end of the roof panels with the manual seaming tool as described in section 6.0.

7.0 OPERATING THE MOTOR SEAMING MACHINE (Cont'd.)

7.5 Clean the Seams

The roof panel seams must be thoroughly cleaned of abrasive dirt or dust that can cause scuffing or scratching of the seam surface. The roof panel seams must be cleaned of grease or other contaminants which can cause seaming machine slippage and marking of the seam surface.

7.6 Running the Machine

Check that the machine's path is clear of power cords, tools, debris, teather lines, etc.

Start the machine by turning on the machine's toggle switch.

Watch the machine and finished seam carefully for any indications of machine malfunction or faulty seaming.

7.7 Stopping the Machine

Stop the machine by turning off the machine's toggle switch.

Always allow sufficient space for the machine to coast after turning the machine off.

Do not run the machine into previously installed end dams or other obstructions.

Note: The **QuadLok** seam will stop just short of the installed end dams approximately 12". The seam should already be **TripleLok** hand seamed at the ridge prior to installation of the end dams. The end dams are designed for **TripleLok** seams only. This is does not affect the performance of the roof system.

7.8 Un-locking the Machine

After the machine is turned off and has fully stopped, lift up the locking handle to the open position to un-lock the machine from the seam.

Using the lift handle, the machine can be lifted from the seam.

7.9 Checking the Finished Seam

At the completion of each seam, check the full length of the seam for any indications of faulty seaming. Refer to section 6.9 for details of the correctly formed finished seam.

The seaming operation exerts high pressure bending forces on the seam. Under such conditions, minor burnishing, pressure marks, and balck oxide marking of the seam surface is normal.

Caution: The seaming machine must always be in the vertical position while seaming. Do not allow the machine to tilt sideways when locking the machine onto the seam or while the machine is running. On roofs with high stand-off clips, walking or standing on the panel next to the machine can deflect the panel and cause the machine to tilt. Do not walk or stand on the panel next to the machine while it is running.

Caution: Stop the machine immediately and investigate any indications of machine malfunction or faulty seaming.

If the machine does not correctly form the seam, do not continue seaming but call BSB for instructions.

If the machine must be stopped and removed before completing the seam, use a felt marker to mark the position of the machine's front wheel on the panel. The machine can later be repositioned on the mark to complete the seaming.

Caution: Black oxide marking is often mistaken to be damage of the seam surface. Objectionalble black oxide can be removed with mild cleaning solutions or solvents.



7.0 OPERATING THE MOTOR SEAMING MACHINE (Cont'd.)

7.10 Bi-Directional Seaming Machine Nomenclature

The following details identify the operational parts of the bi-directional “flip-flop” seaming machine.

The cam follower will be on the side of the TripleLok set-up.

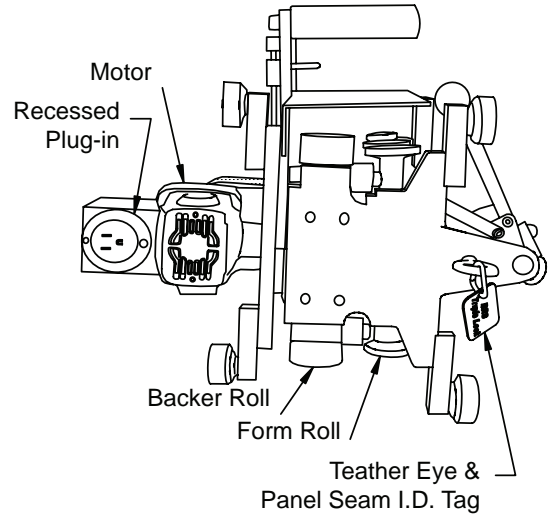
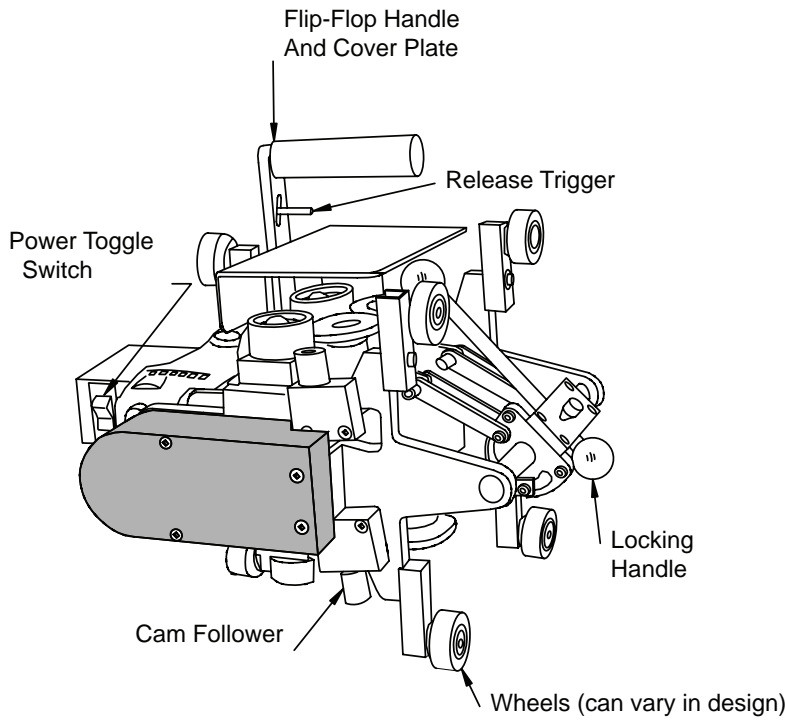

7.11 Difference in Seaming Direction

This machine is a very unique labor saving machine because it can form bi-directionally or can be two machines in one. The **TripleLok/TripleLok** machine can be run from eave to ridge the “flipped” to run ridge to eave on the adjacent seam to save “drag back” time.

The **TripleLok/QuadLok** machine can be run from eave to ridge as **TripleLok** then be “flipped” to run from ridge to eave on the same seam to form **QuadLok**.

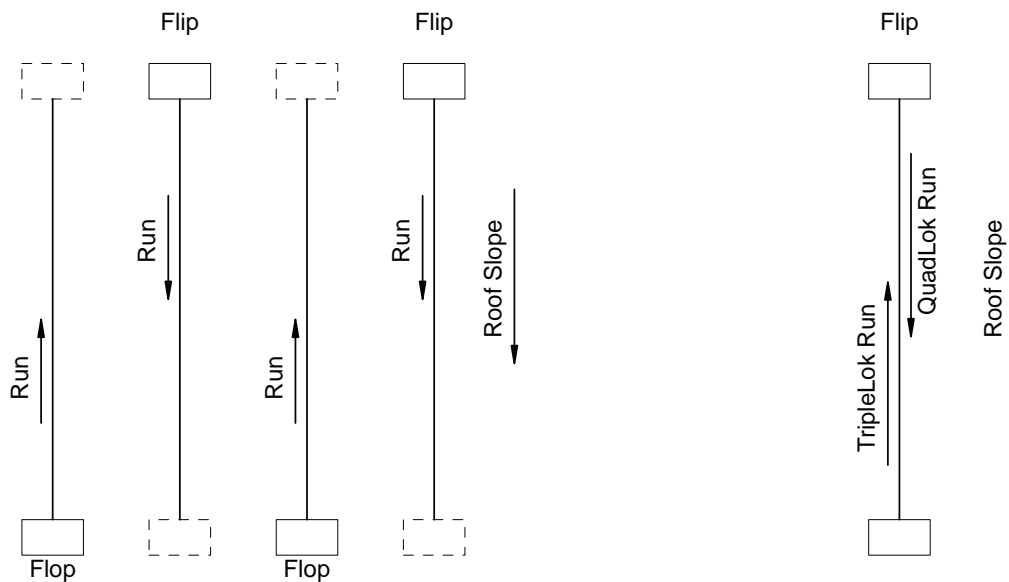

7.0 OPERATING THE MOTOR SEAMING MACHINE

7.12 Locking the Machine to the Seam

When the machine is in the correct position on the seam, pull the locking handle out to the locked position. The locking handle should lock with minimal resistance when force is applied.

If the locking handle will not readily lock, roll the machine forward or backward slightly until a position is found where the locking handle will readily lock.

If the locking handle still does not lock, check the hand seaming to be sure it is in the proper form.

Once the locking handle is locked, check that the forming rolls are properly engaged.

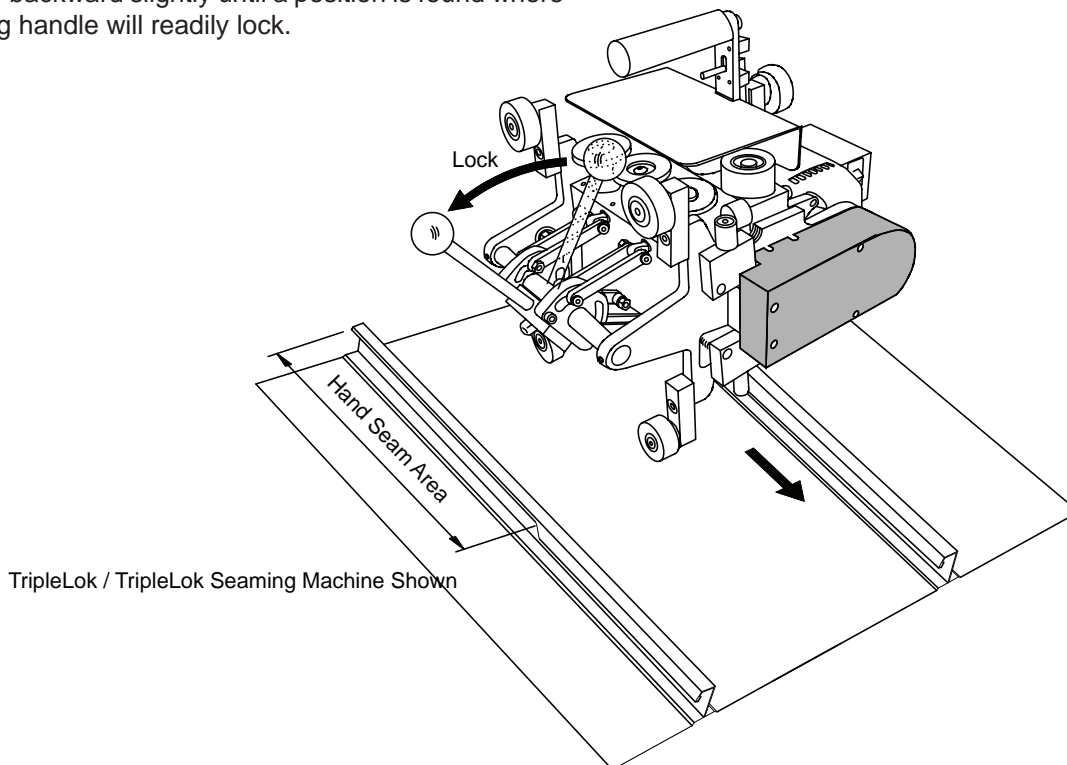

7.13 Starting the Seaming Process

The basic seaming process of starting, running and stopping the bi-directional “flip-flop” machine is the same as described in the one direction seaming machine operation.

Follow the same basic safety tips such as use of teather lines, stopping the machine near the eave and ridge etc.

Note: The **QuadLok** seam will stop just short of the installed end dams. The seam should already be **TripleLok** hand seamed at the ridge prior to installation of the end dams. The end dams are designed for **TripleLok** seams only. This does not affect the performance of the roof system.

7.14 Un-locking the Machine

After the machine is turned off and has fully stopped, lift up the locking handle to the open position to un-lock the machine from the seam.

Using the lift handle, the machine can be lifted from the seam.

If the machine must be stopped and removed before completing the seam, use a felt marker to mark the position of the machine’s front wheel on the panel. The machine can later be repositioned on the mark to complete the seaming.

7.0 OPERATING THE MOTOR SEAMING MACHINE

7.15 Flipping the Bi-Directional Seaming Machine

Flipping the machine to change the seaming direction is a three step process. The machine will need to be held aloft during this process in order to not damage the panel finish.

Step 1. Using your index finger, lift up on the release trigger until you hear or feel the top plate disengage.

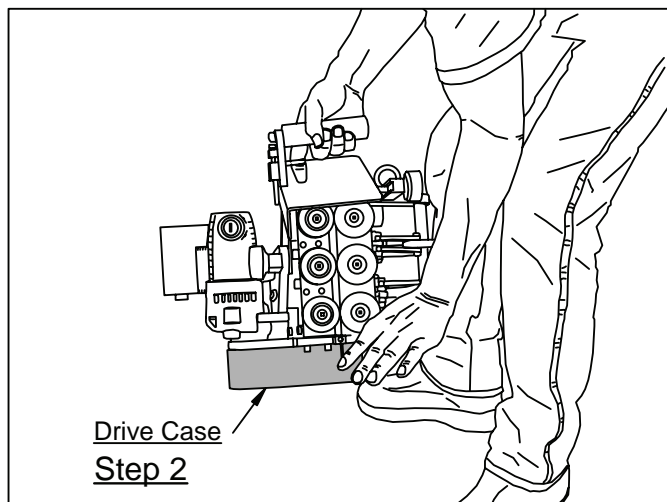
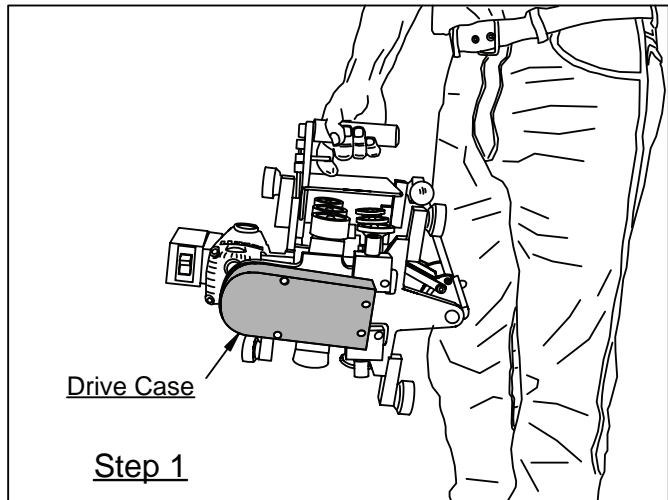

Step 2. While still holding seamer aloft, use your free hand to rotate the form rollers to the next stage.

Step 3. Continue to rotate the unit until the release trigger re-engages and is stabilized with a clicking sound. The unit is now ready to be set onto the next work area.

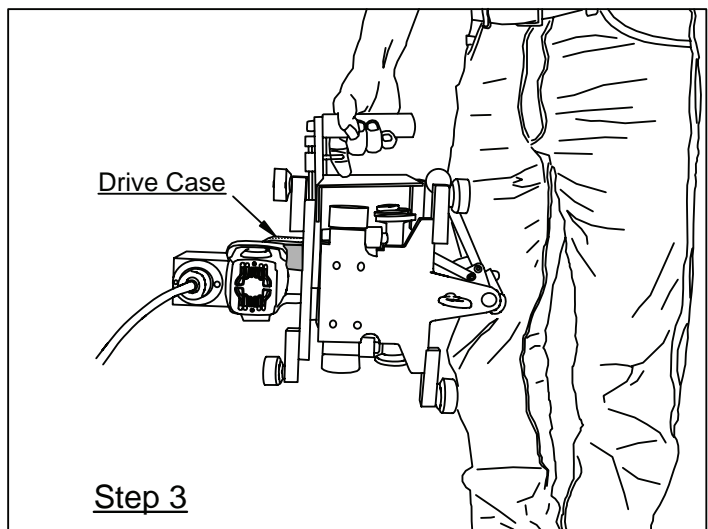

8.0 MOTOR SEAMING MACHINE MAINTENANCE

8.1 General

The motor seaming machine is a precision fabricated, high performance, portable roll forming machine. This relatively lightweight machine does the tough job of forming the extra strong **TripleLok** and **QuadLok** seams under often rugged field conditions.

Although designed for tough industrial use, the seaming machine requires proper maintenance to assure proper seaming and efficient, trouble free operation.

8.2 Seaming Rolls

The seaming rolls require the following regular maintenance:

- a. Assure that the seaming machine's seaming rolls are free of dirt, grease, sealant, etc.
- b. Spray the seaming rolls with WD-40 (or equal) to prevent corrosion and minimize Galvalume build-up on the rolls.
- c. Assure that the seaming machine's seaming rolls are tight on their shafts. Check and tighten the rolls' retainer screws as necessary.
- d. On painted roofs, especially during very hot or abrasive conditions, spraying or misting the seams with

Caution: Failure to properly maintain the seaming machine as instructed below can result in faulty or damaged seams and costly break-down of the seaming machine.

water, or a light lubricant such as WD-40, ahead of the seaming machine may significantly reduce burnishing and oxide marking of the seam surface.

- e. On very dry Galvalume roofs, spraying or misting the seams with water, or a light lubricant such as WD-40, ahead of the seaming machine may significantly reduce seaming friction and Galvalume build-up on the seaming rolls.
- f. When QuadLok seaming, the increased seaming pressures may require spraying the seam with a light lubricant, such as WD-40, ahead of the seaming machine to reduce burnishing or abrasion of the seam surface.

8.3 Cooling Vents

To prevent motor overheating, the motor has vents and an internal fan to provide a cooling air flow over the internal motor parts.

The cooling vents are located at the front and rear of the motor. At the front of the motor, the vents are the slots between the motor housing and the gear box. The rear vents are on the end of the motor housing. Check frequently to

assure that these vents are kept clean and clear of debris, stringing sealant, etc.

While the machine is running, never cover the machine or place it in a position where the cooling air flow to the vents will be restricted.

